

Fig.1 - Schema della rete ferroviaria lombarda

SCHEMA NODO DI TREVIGLIO

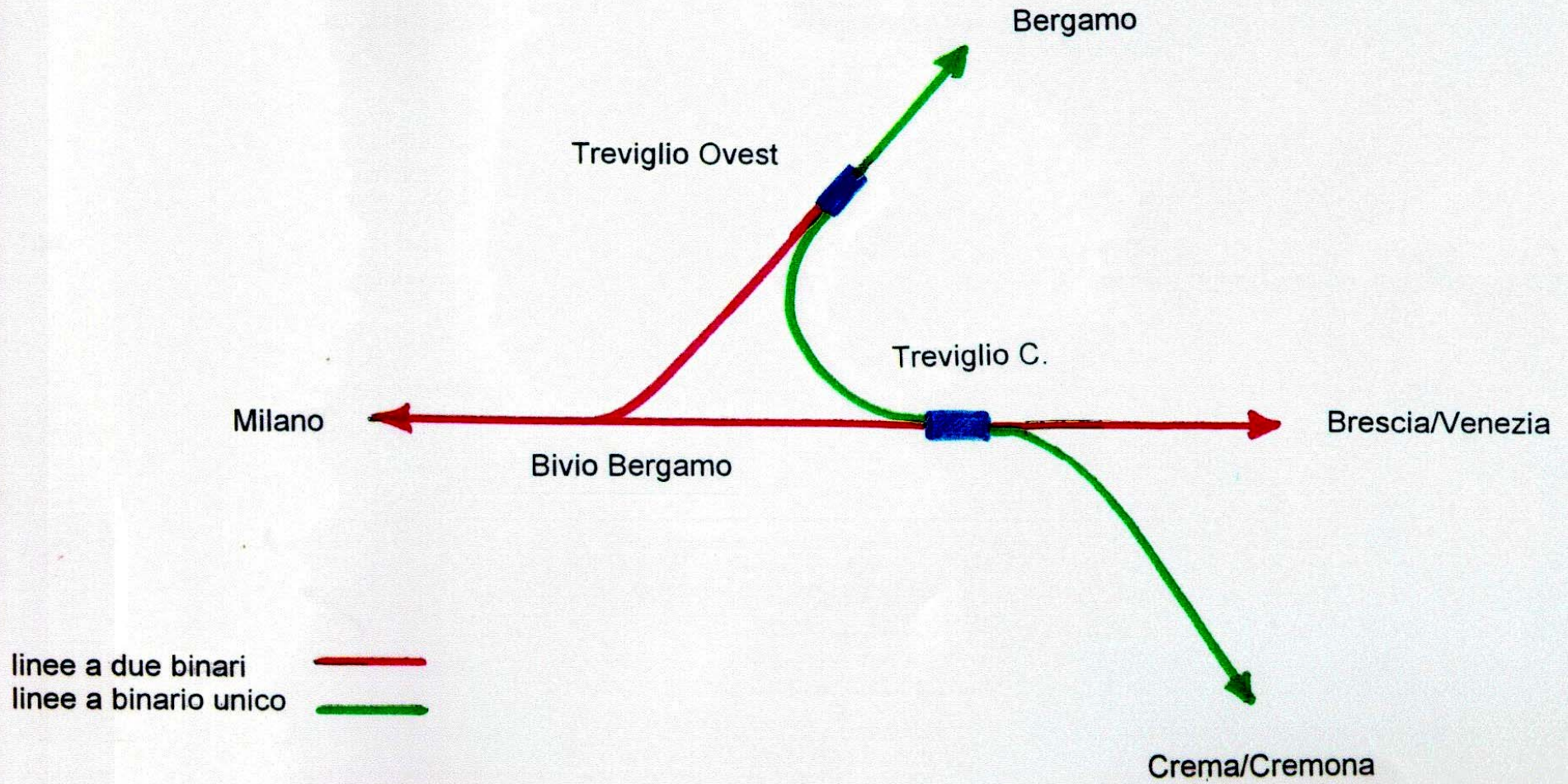


FIGURA 2

Treviglio

FIGURA 3

Milano

Brescia

- autostrada —
- SS Paullese —
- linee ferroviarie —

A21 - Brescia

Brescia

Codogno

Mantova

A21 - Torino

Piacenza

Fidenza

A21

Parma

Le ferrovie nel territorio della
Provincia di Cremona

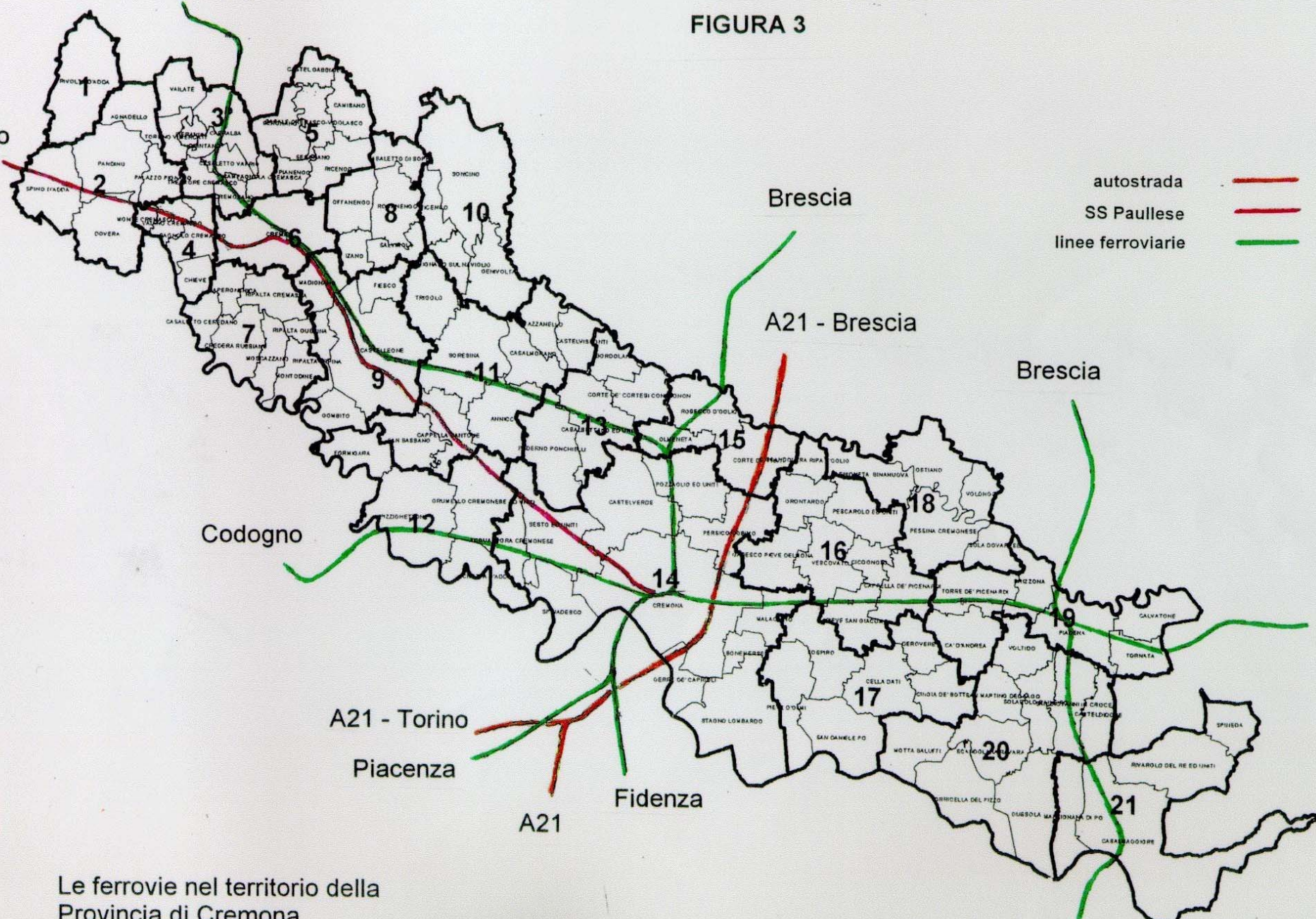
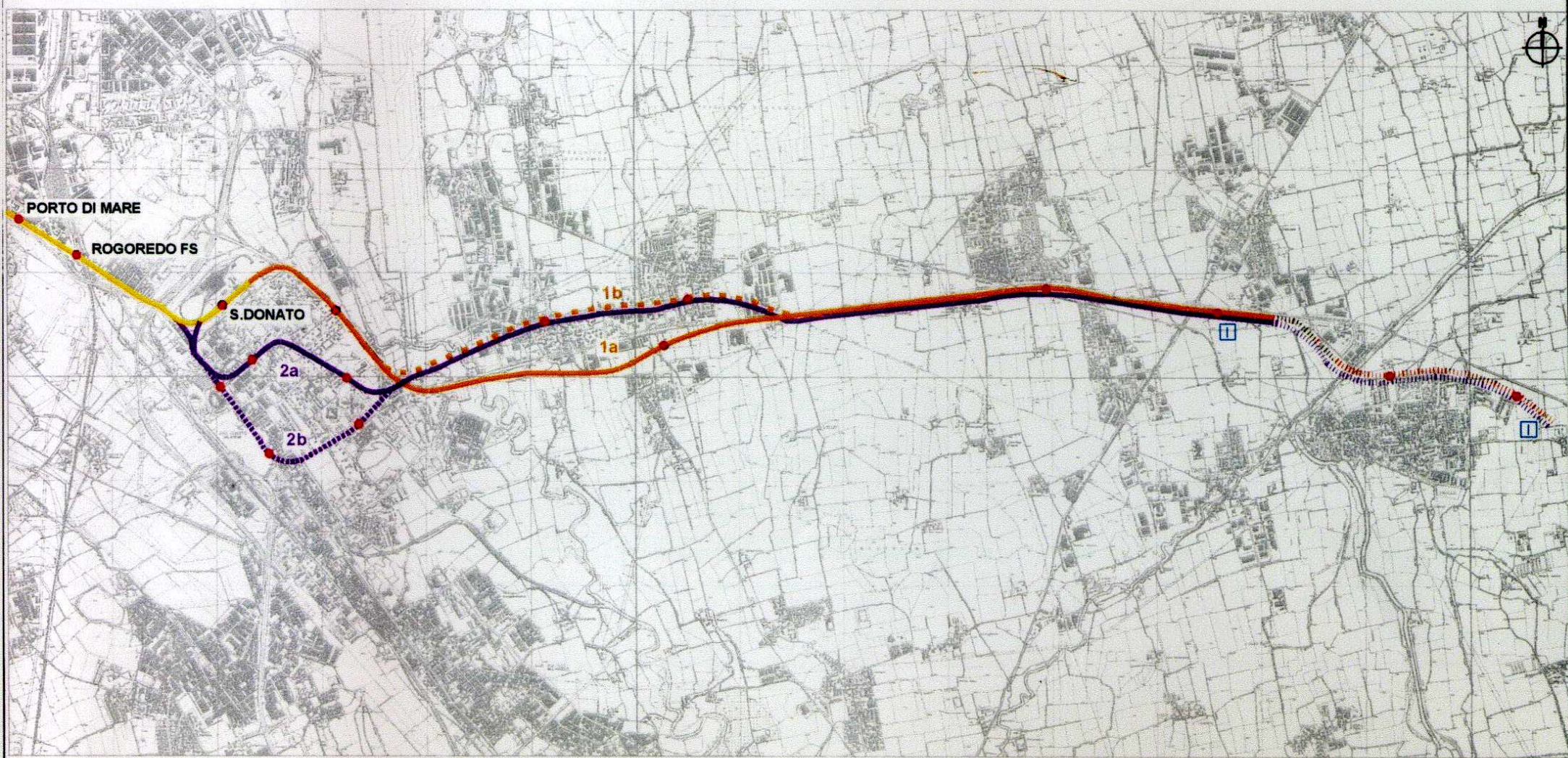


FIGURA 4



- soluzione 1a
- - - soluzione 1b
- soluzione 2a
- - - soluzione 2b
- - - - - ulteriore estensione

Progetto prolungamento linea metropolitana M3
lungo la direttrice Paullese - fonte: Studio MM [2]



Direttrice sud - est " SS 415 Paullese"
Estensione linea M3 S. Donato - Paullo
Alternative di tracciato - Corografia

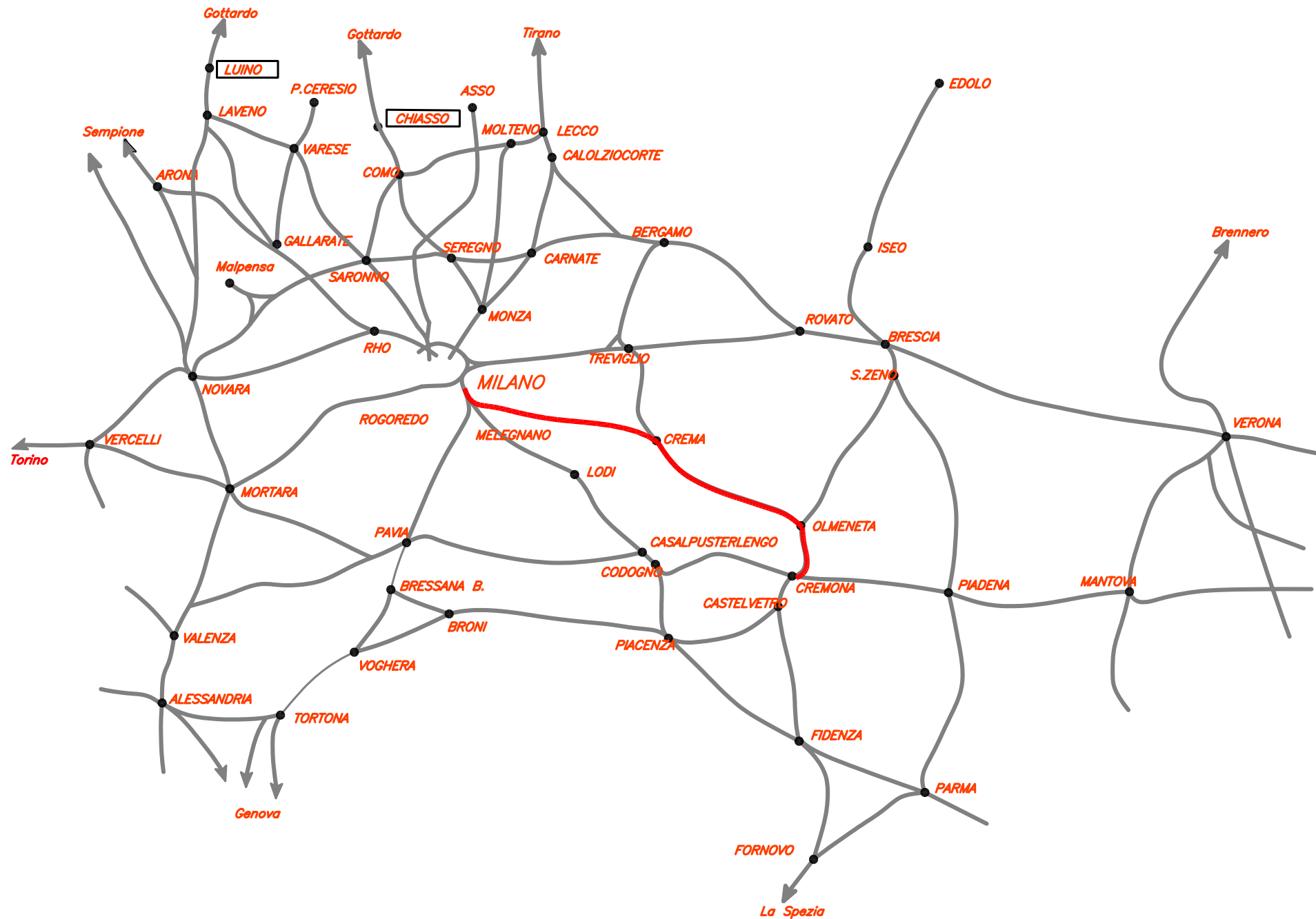


Fig.5 - Proposta di una linea ferroviaria diretta Milano - Crema

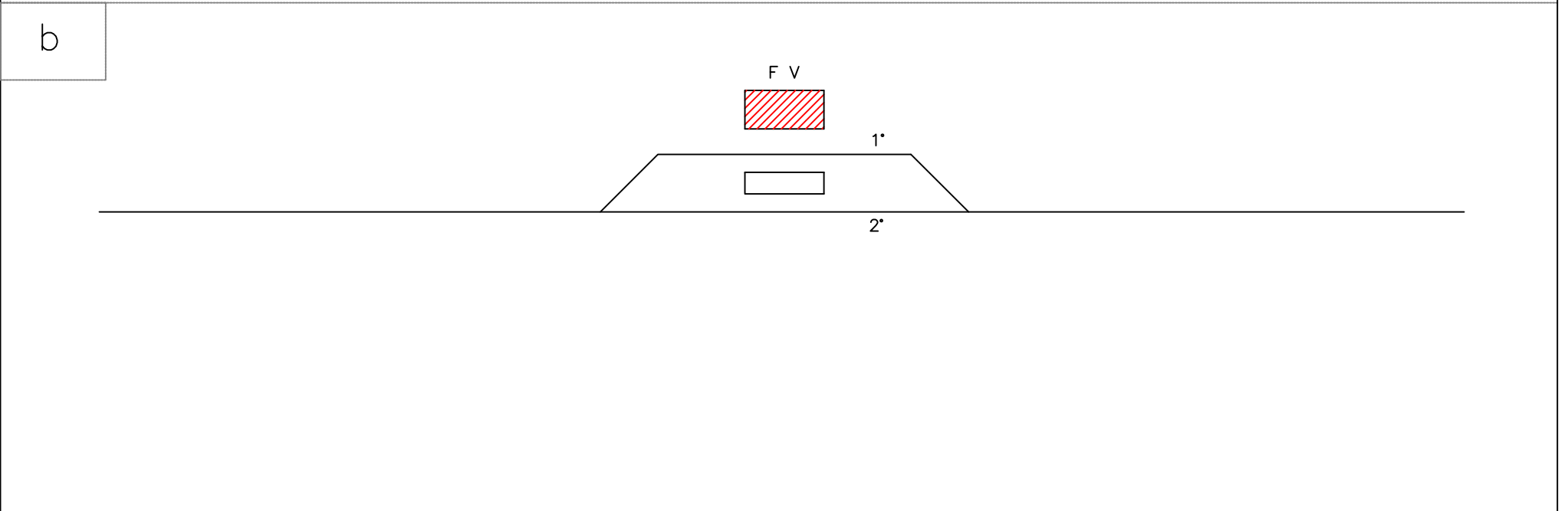
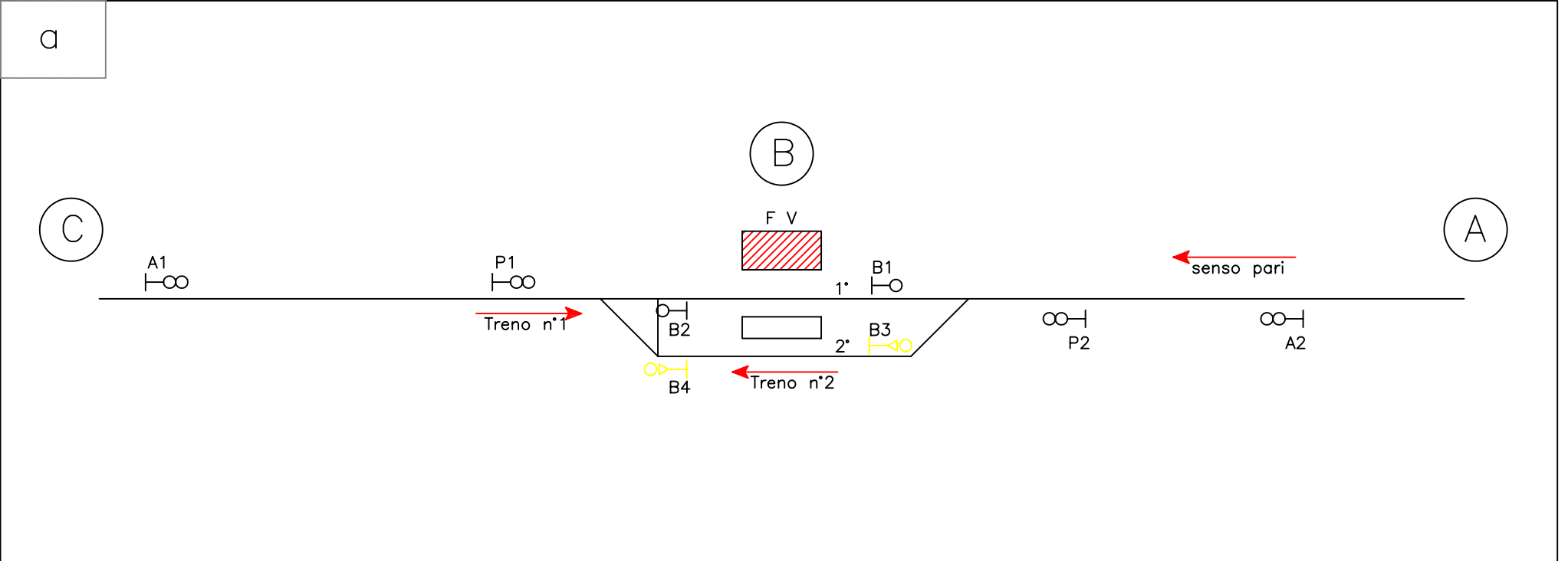


Fig. 6

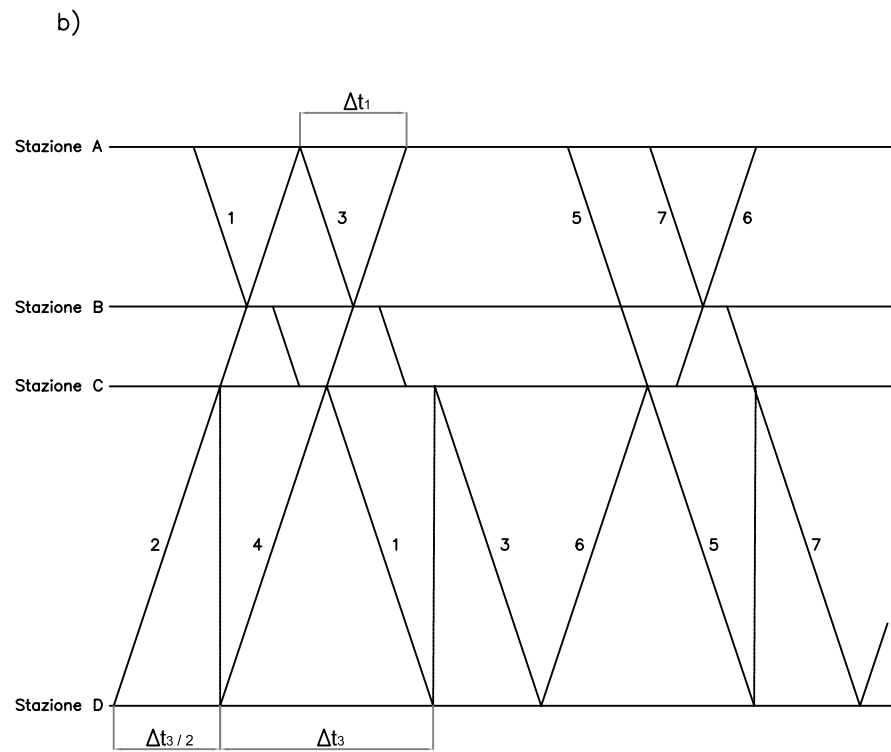
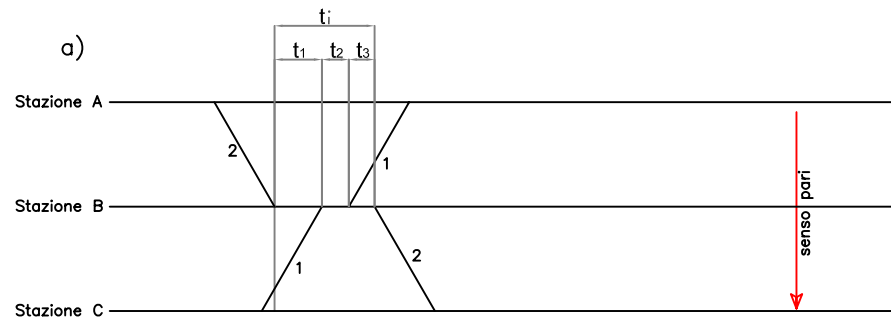


Fig. 7

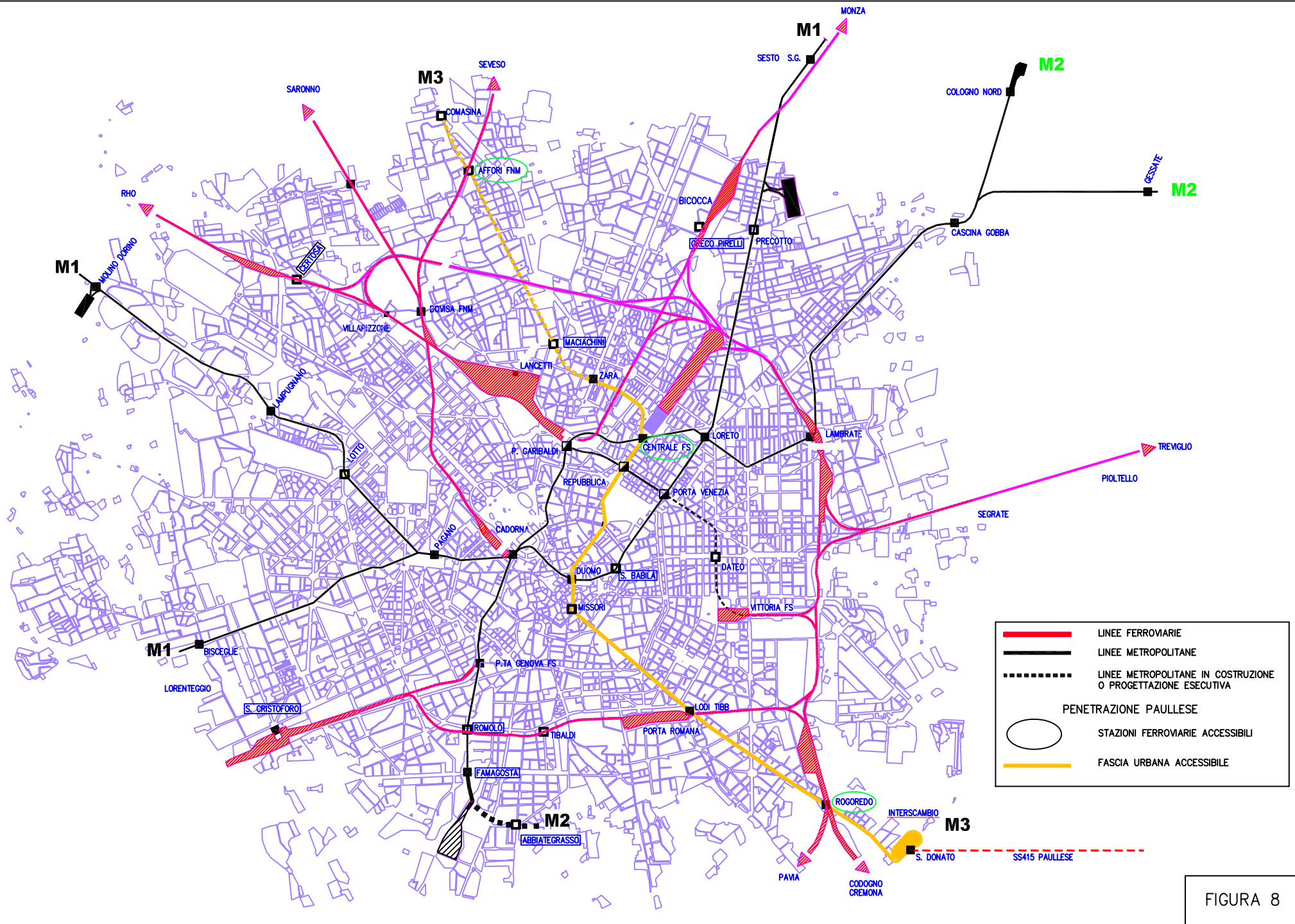


FIGURA 8

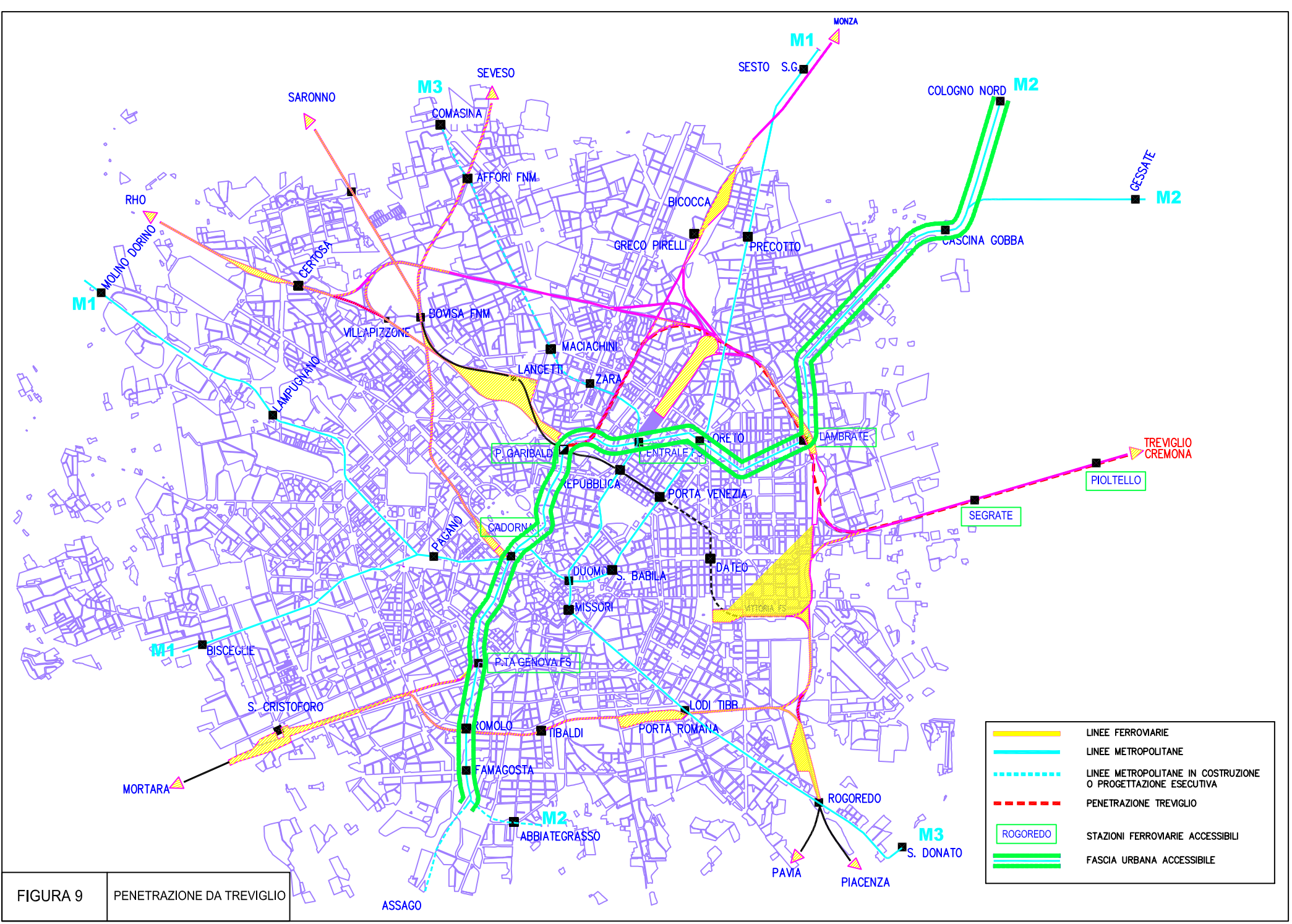


FIGURA 9 PENETRAZIONE DA TREVIGLIO

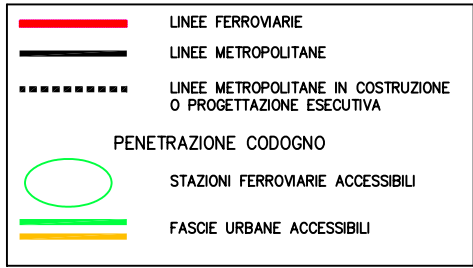
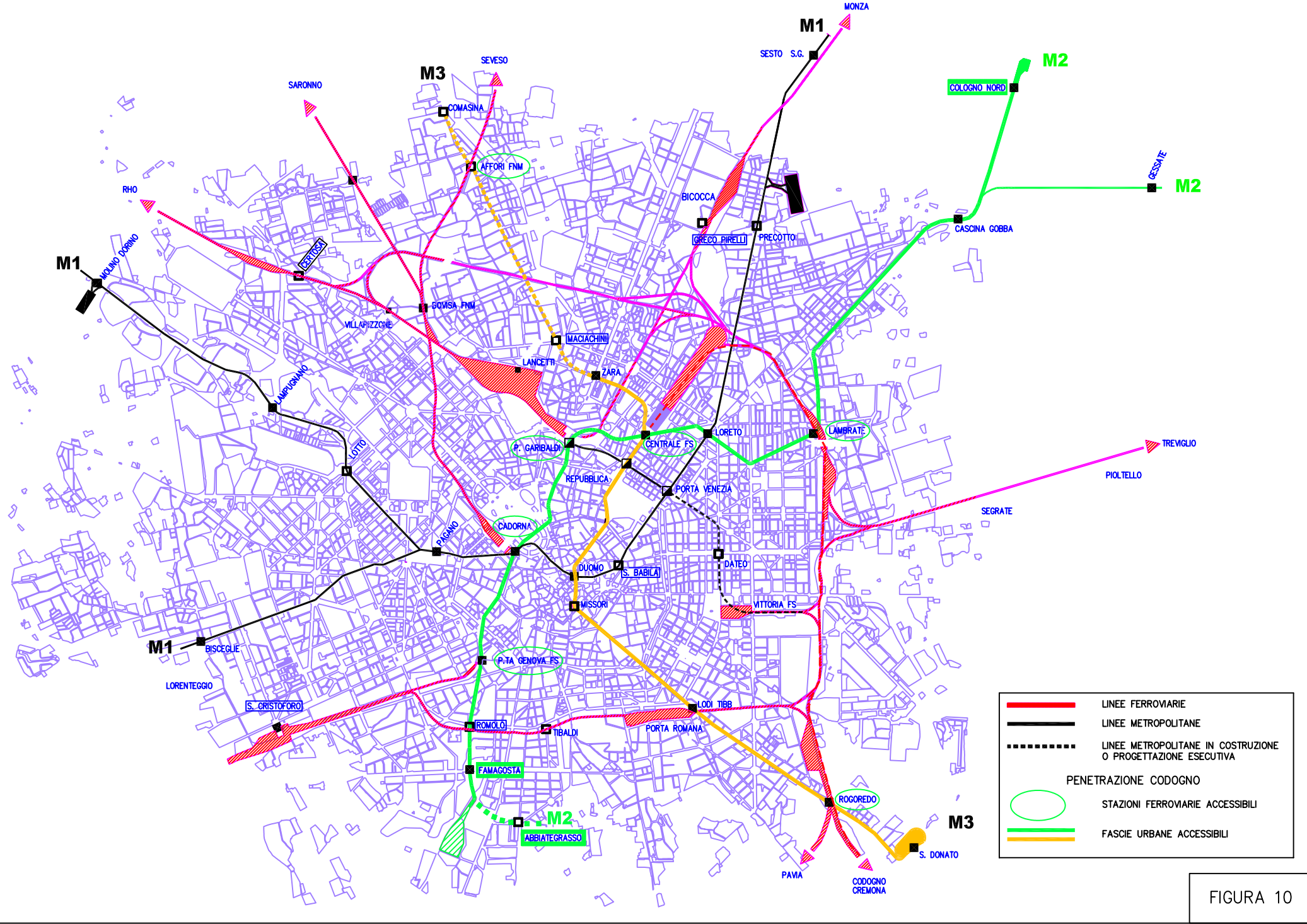


FIGURA 10

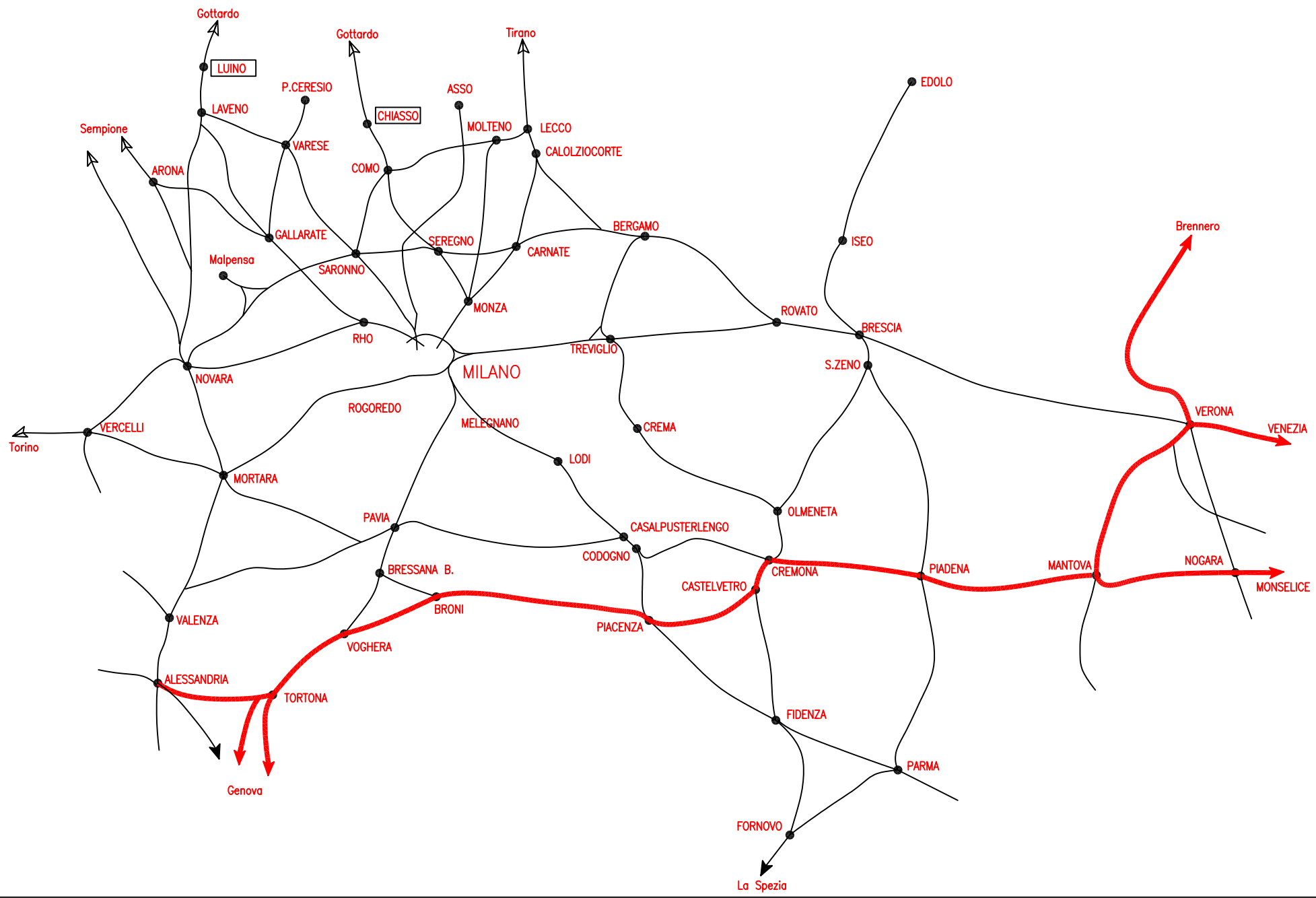


Fig.11 – Itinerario "basso" e "medio" padano

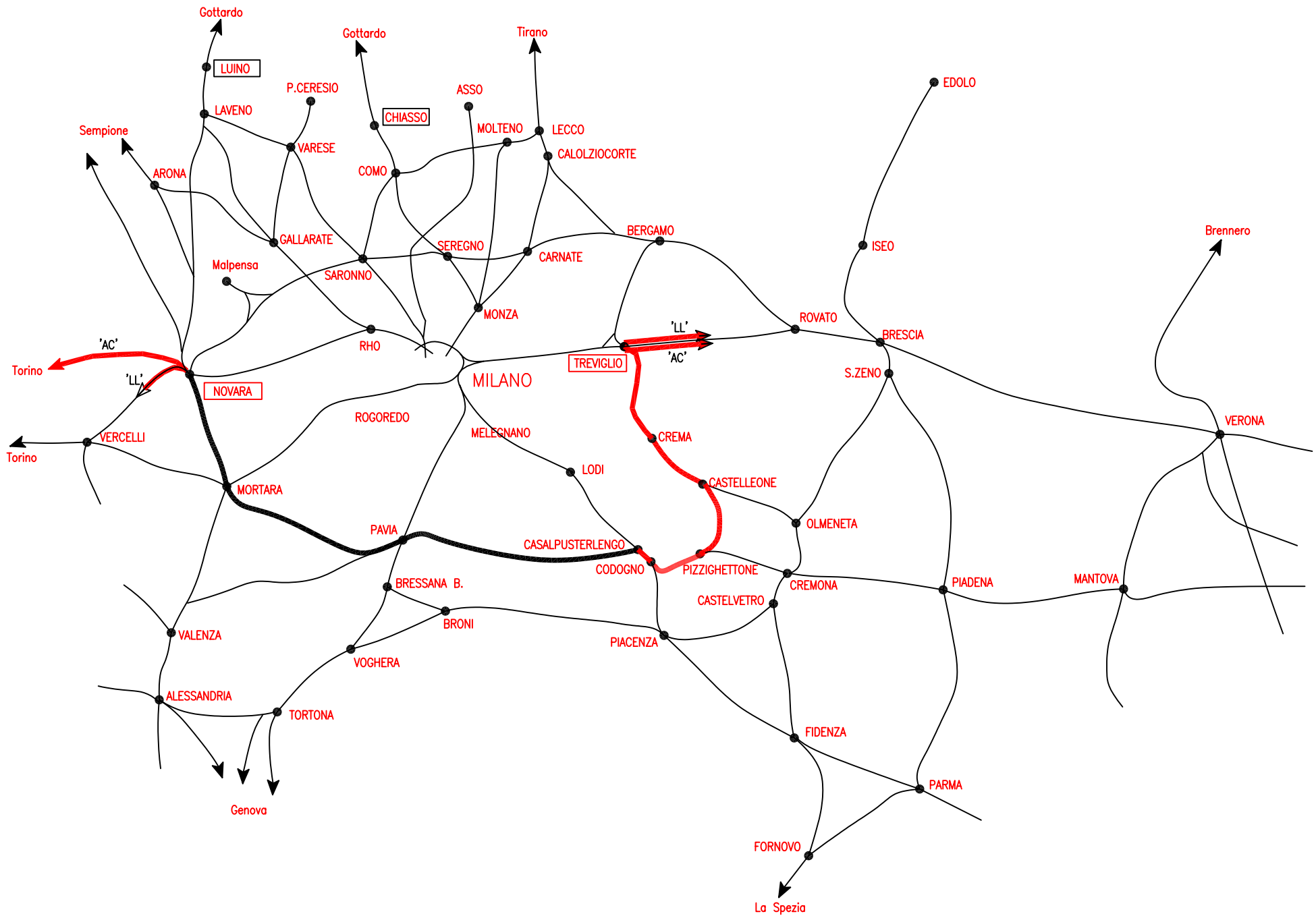


Fig.12 - La "gronda sud" di Milano

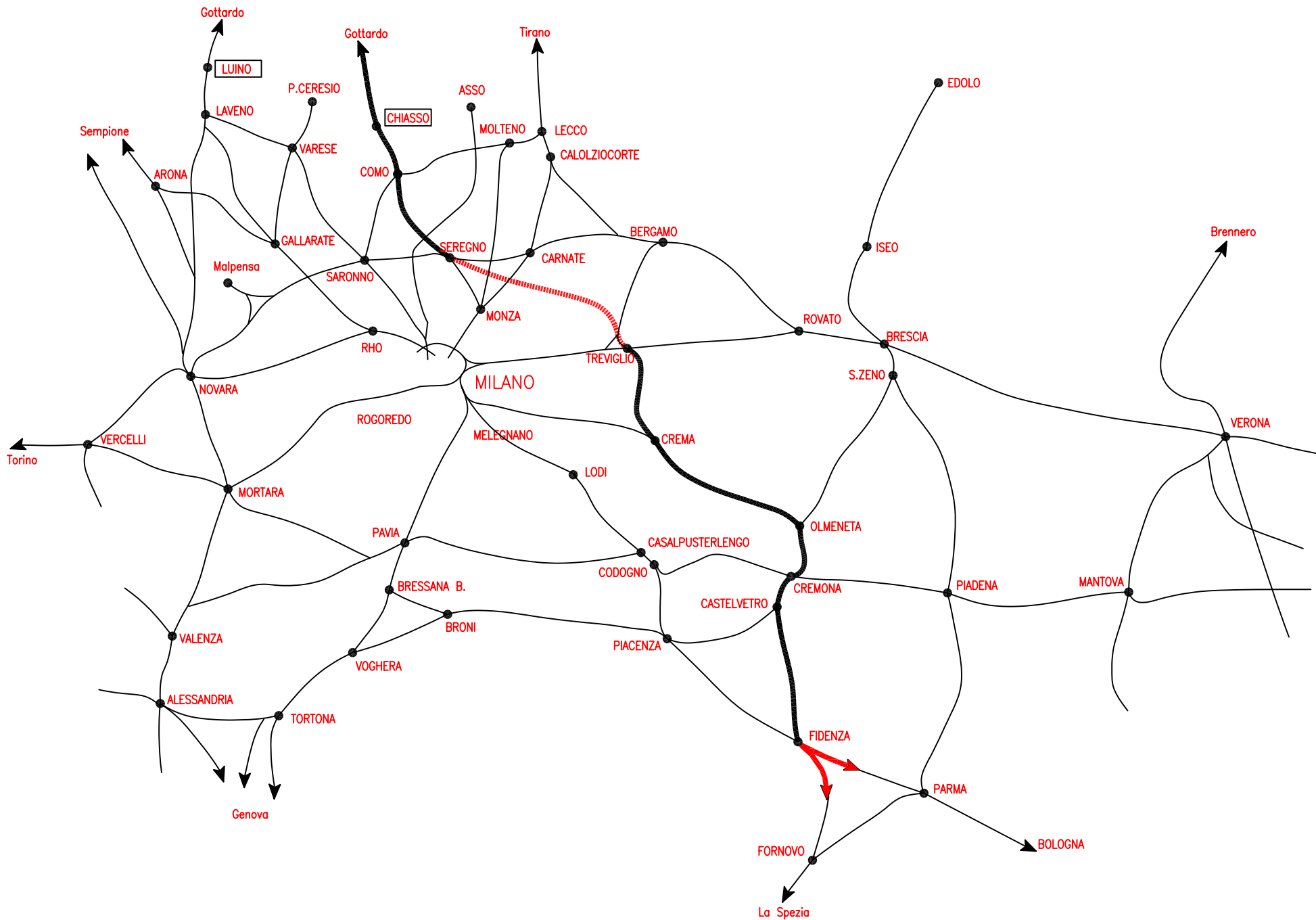


Fig. 13 – Itinerario longitudinale est

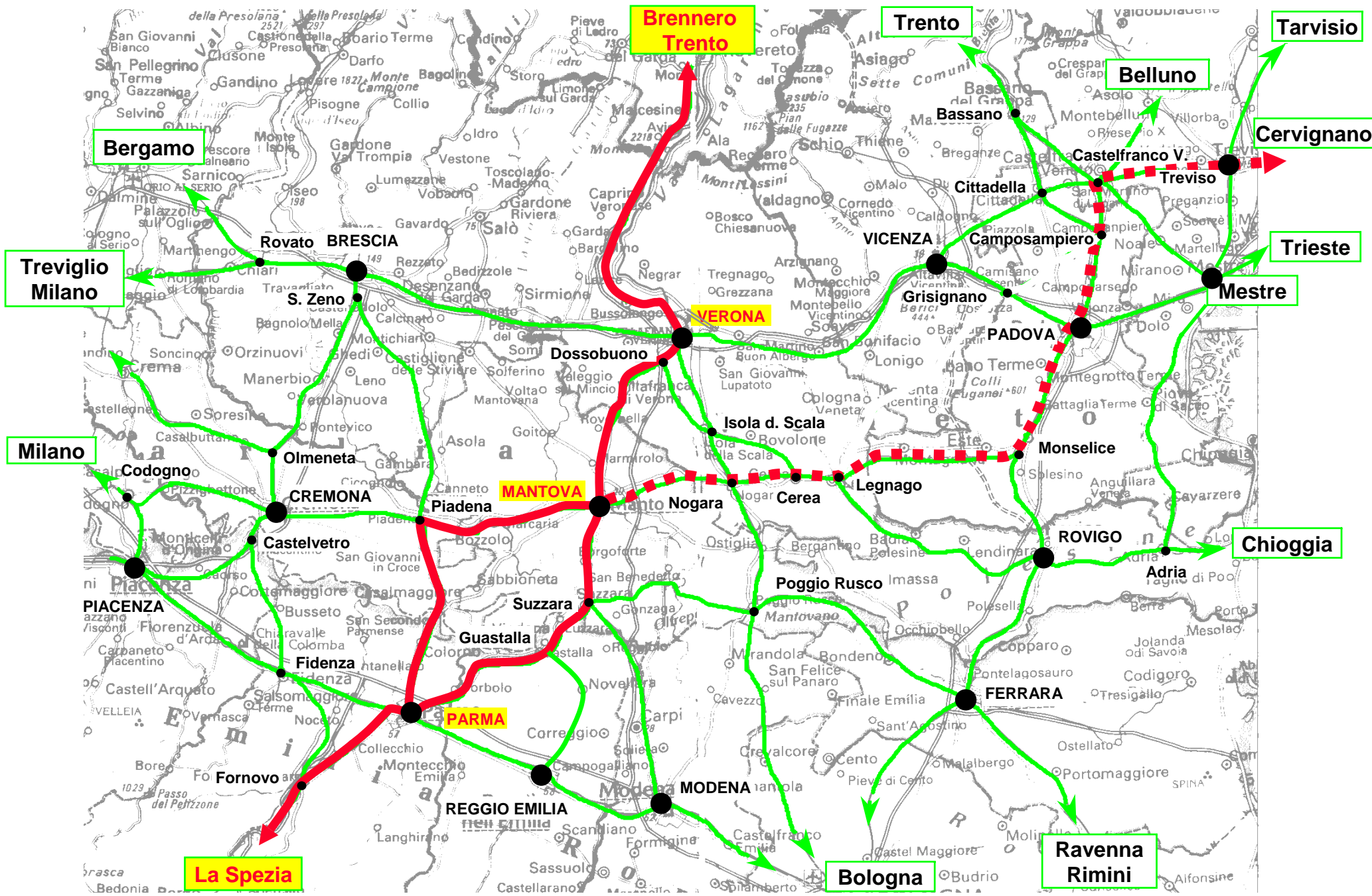
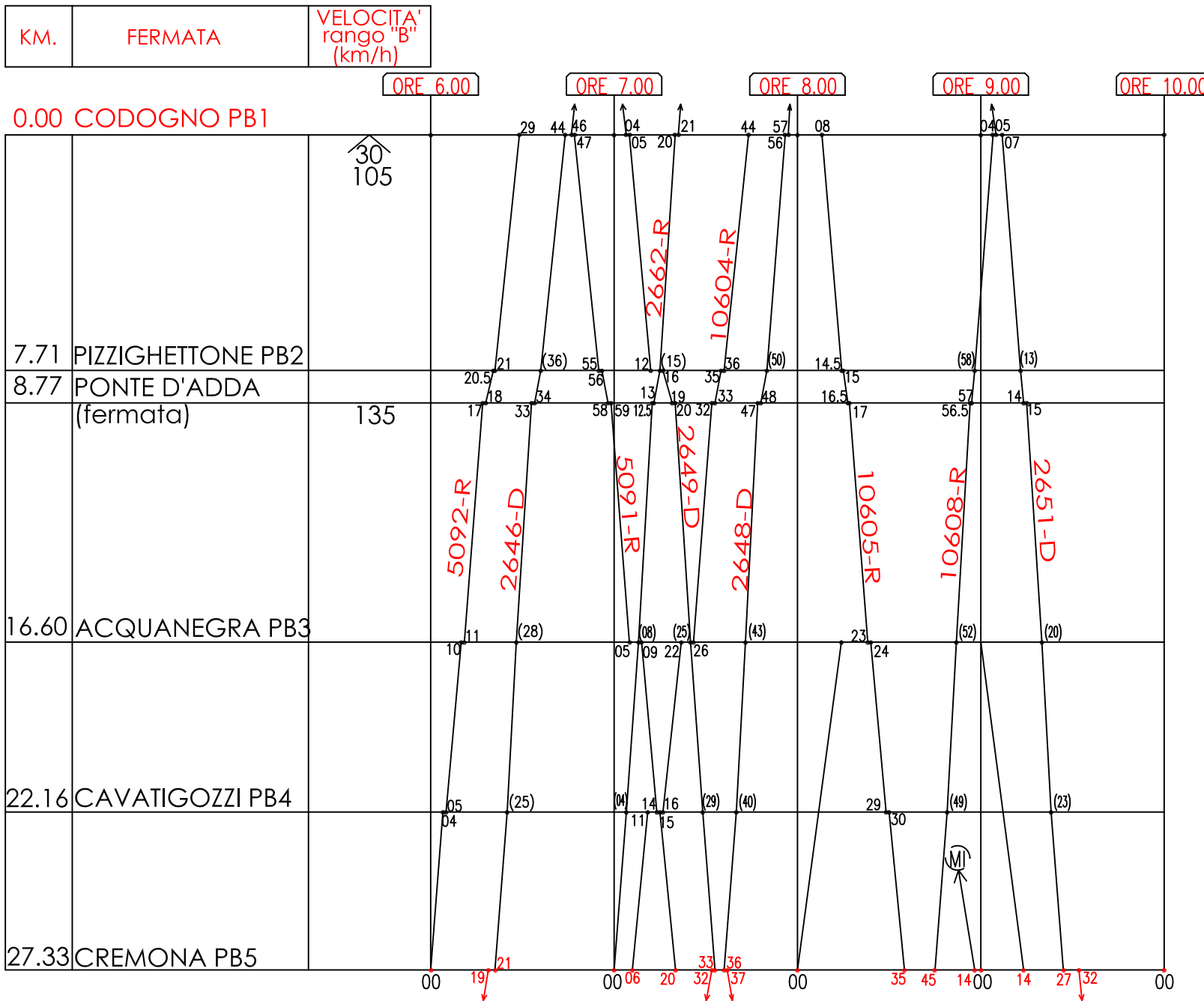


Fig. 14 - Il corridoio ferroviario TI.BRE.



LEGENDA:

- TRENII PASSEGGERI
- TRENII MERCI
- (-- --) ORARI TRANSITI

NOTE:

- 2662 e 10608 : Classificati "R" , impostati come "D"
- Fermata 2662 a Pizzighettone : di servizio (incrocio con 2662)